

2 - Hood

CODE	DESCRIPTION
120356	DOOR MAGN.SWITCH
160720	PLUG HEYCO D.8
160836	DOOR WASHER BR-BC-FC
180506	DOOR CATCH BR-BC-FC
260106	SCREW TE 6X25
260126	SCREW TE 5X12
260403	NUTS D.5
260405	NUT D.8
260412	SELF-LOCKING NUT M6
260503	STAINL.STEEL FLAT WASHER D5 UN
260504	ST/ST FLAT WASHER D6
260505	STAINL.STEEL FLAT WASHER D8
331208	ST.STEEL FOOT
H15568	DOOR PIN FOR DOOR GF70/90
H15995	BUSH
H17582	THERMOSTAT BRACKET
H25006	NUT FOR HOSE H26556
H25202	PAD FOR DOOR GF90
H25700	SCREW TC 4X8
H26284	BRACKET
H26556	HOSE
H26751	SCREW TC 6X12
H29594	BLIND NUT M4
H30438	SPRING
H32969	DOOR MAGNET
H33179	S/S NUTS 4MA
H33344	PASSACAVO GFS90
H33745	THERMOSTAT 110Ø
H34429	SCREW
H34445	CONNECTOR GF90
H35264	RIGHT RACK GUIDE GF90
H35265	LEFT RACK GUIDE GF90
H36004	PAD FOR DOOR GF90
H36034	HANDLE GFS90
H36660	COVER GFS90
H36733	DOOR FRONT PANEL GFS90
H36734	PANEL FOR DOOR GF90
H36872	COMPLETE DOOR GFS90
H37233	HOOD GFS90
H37234	FRONT PANEL GFS90
H37235	BACK PANEL GFS90
H37236	SCHIENALE CARROZZERIA GFS90
H37293	CENTRAL PANEL
H37337	DOOR SPRING
H37530	TAPPO CHIUSURA FORO SERBAT.BT

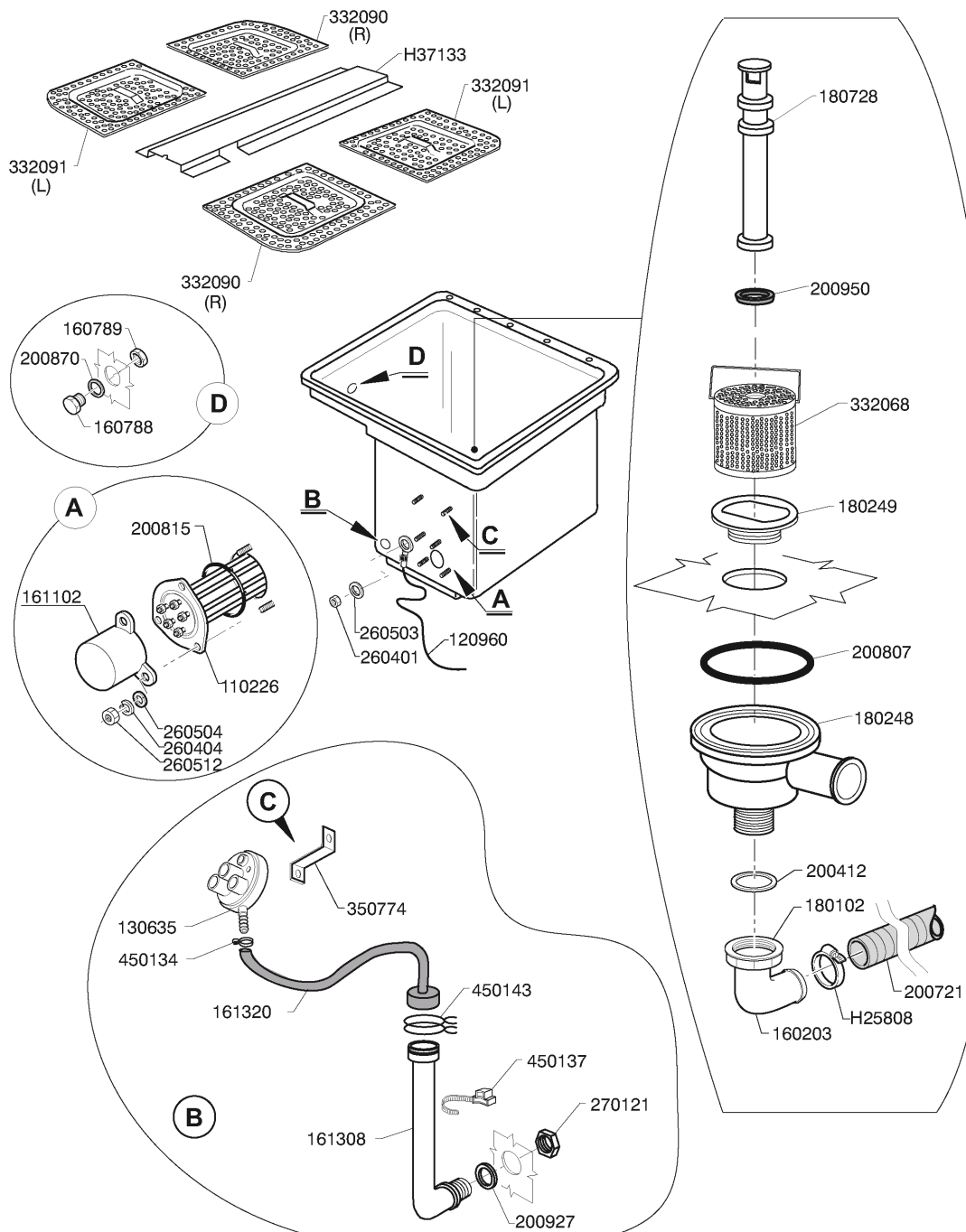

MS 06-2010

3 - Tank

CODE	DESCRIPTION
110226	HEAT. ELEMENT 3000W 230/400V
120960	PROBE C-G
130635	PRESSURE SWITCH 190-40
160203	ELBOW 1"1/2 N-S-F-C /DRAIN
160788	PLUG
160789	NUT
161102	ELEMENT COVER MOPL.
161308	AIR CHAMBER C95-155
161320	HOSE FOR AIR CHAMBER
180102	DRAIN PIPE NUT 1"1/2 F45-55
180248	SUCTION TANK
180249	NUT
180728	OVERFLOW PIPE
200412	GASKET DRAIN 11/2" 45X33X3
200721	DRAIN HOSE 28X35 2MT.
200807	O-RING 3,53 X 110,72
200815	O-RING F. HEAT.ELEM.
200870	GASKET 18X10X2
200927	GASKET FOR AIR TRAP
200950	VITON GASKET
260401	NUT 3MA
260404	STAINLESS STEEL NUTS D6 UNI 55
260503	STAINL.STEEL FLAT WASHER D5 UN
260504	ST/ST FLAT WASHER D6
260512	ST/ST GROWER WASHER D6
270121	NUT FOR AIR TRAP
332068	STRAINER
332090	RIGHT STRAINER
332091	TANK LEFT STRAINER
350774	BRACKET
450134	ELASTIC HOSE CLIP D.9,3/8,8
450137	COLLAR CONNECTION WITH BASE 31
450143	CLAMP D.39,7 X 37,7
H25808	CLAMP
H37133	FILTER SUPPORT GFS90

4 - Wash/Rinse column

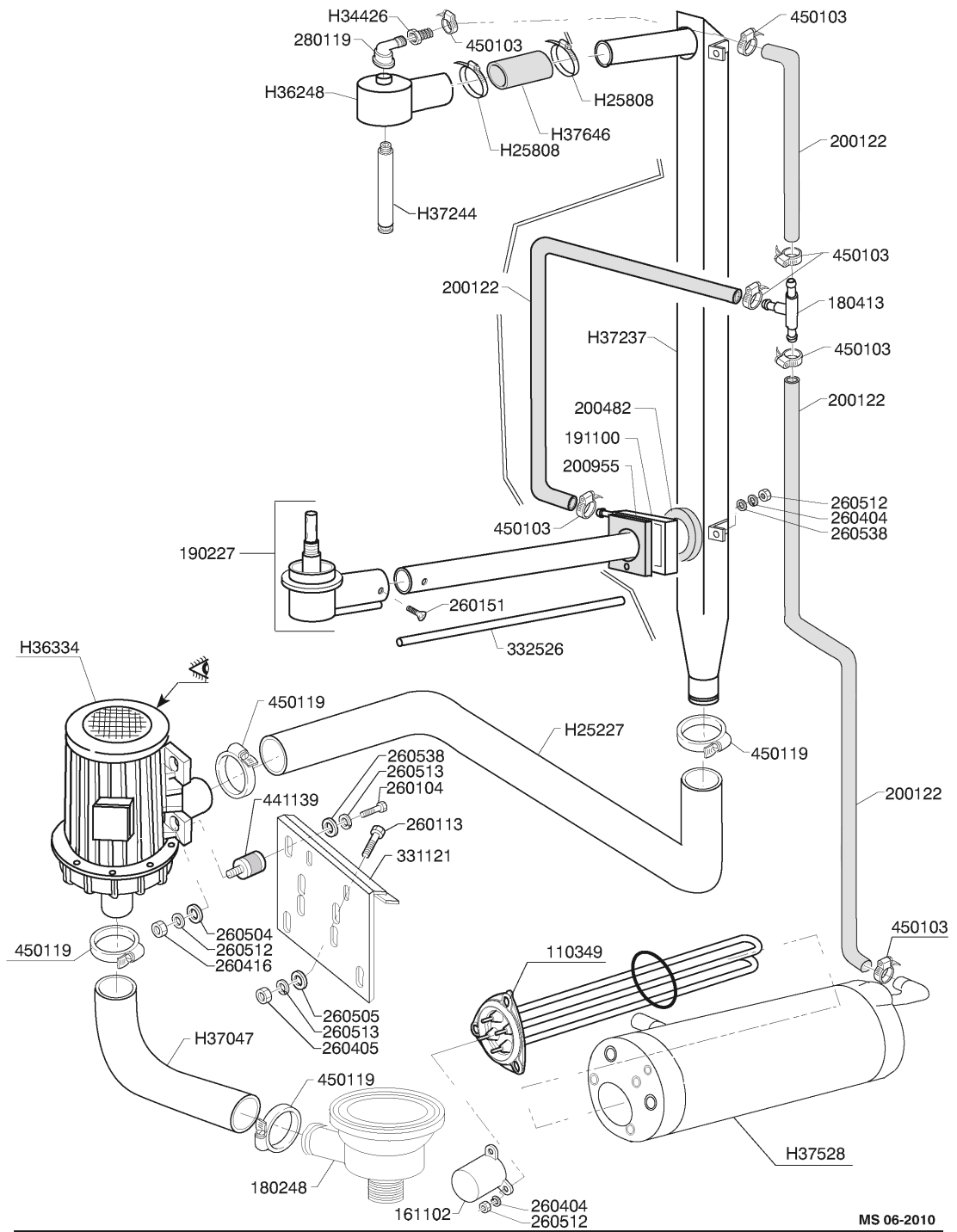

MS 06-2010

4 - Wash/Rinse column

CODE	DESCRIPTION
110349	HEAT.ELEMENT 6000W 230/400V
161102	ELEMENT COVER MOPL.
180248	SUCTION TANK
180413	TEE NIPPLE D.11,5 - RINSE ASSE
190227	ARM SUPPORT
191100	RINSE COLLECTOR C-LC
200122	HOSE 11X19
200482	GASKET 60X54 RAMP C140
200955	GASKET
260104	STAINL.ST TE-SCREW A2 6X16 UNI
260113	STAINL.ST.TE SCREW 8X20 A2 UNI
260151	SCREW TE 4X12
260404	STAINLESS STEEL NUTS D6 UNI 55
260405	NUT D.8
260416	STAINLESS STEEL NUTS M6
260504	ST/ST FLAT WASHER D6
260505	STAINL.STEEL FLAT WASHER D8
260512	ST/ST GROWER WASHER D6
260513	GROWER WASHER D8
260538	WASHER 18X6X1,5 ST/ST
280119	ELL MF 3/4"
331121	FIXING PLATE FOR PUMP ACR
332526	RINSE HOSE
441139	VIBRATION-DAMPING FEET 25X20X6
450103	CLAMP FE ZN. 13-20 H=9
450119	CLAMP FE ZN. 58-75 H=12,2
H25227	GE50 PUMP OUTLET HOSE
H25808	CLAMP
H34426	HOSE BARB 1/4
H36248	UPPER WASH ARM HANDLE
H36334	WASH PUMP 2,2HP 230/400-3 50HZ
H37047	PUMP INLET HOSE GFS90
H37237	WASH AND RINSE COLUMN
H37244	UPPER SUPPORT
H37528	BOILER GFS90
H37646	HOSE

5 - Wash and rinse arm

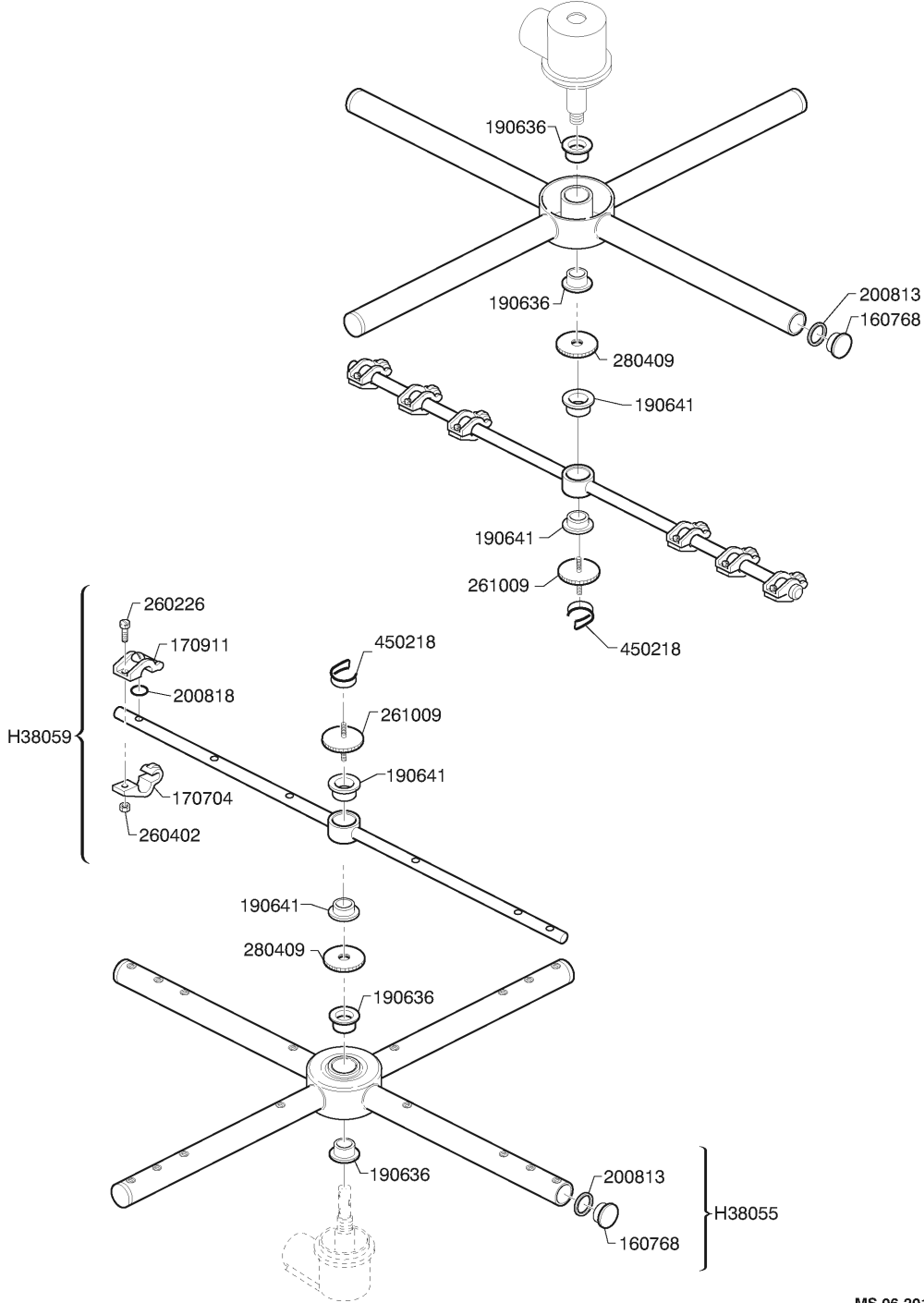

MS 06-2010

5 - Wash and rinse arm

CODE	DESCRIPTION
160768	PLUG FOR "C95-155" WASH ARM
170704	RINSE NOZZLE BOTTOM F-B-C33
170911	RINSE JET B23-F2-C34
190636	BUSH FOR C95-155-165 WASH ARM
190641	BUSH FOR C95-155-165 RINSE ARM
200813	OR GASKET 2,21X16,36X20,78
200818	O-RING 1,78 X 6,75 X 10,31
260226	STAINL.ST TCP SCREW 4X12 A2 UN
260402	STAINLESS STEEL NUT D4 UNI 55
261009	RETAIN.SCREW FOR WASH-RINSE AR
280409	RETAIN.LOCK NUT CENTR.CROSS C1
450218	SPRING F.RINSE ARM RETAIN.SCRE
H38055	WASH ARM XLC/GFS90
H38059	RINSE ARM XLC/GFS90

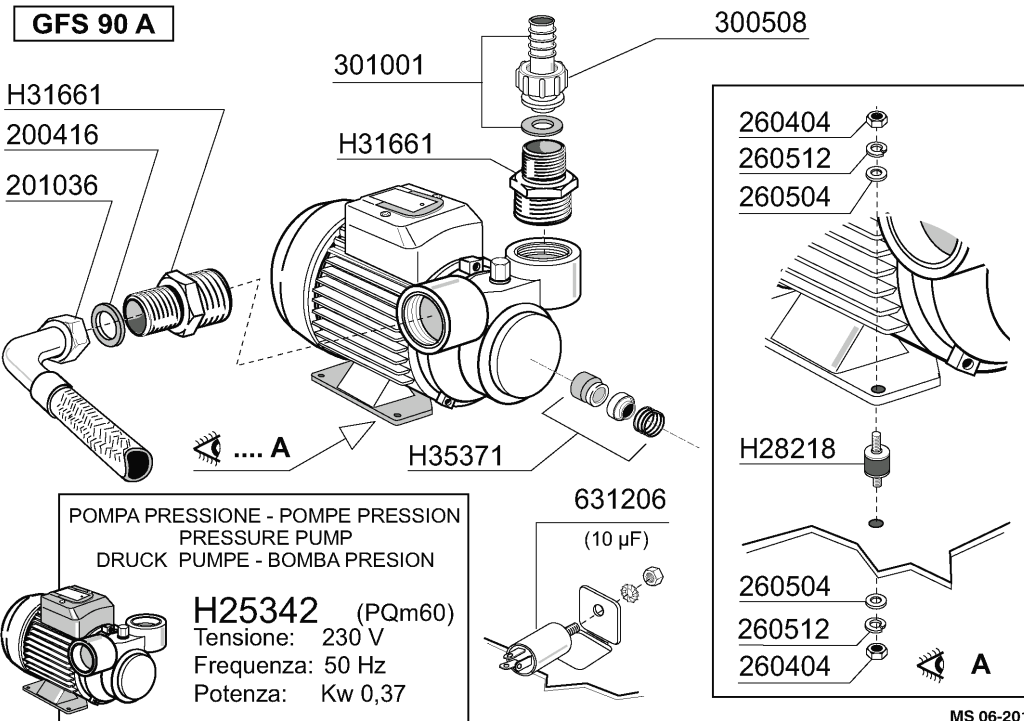
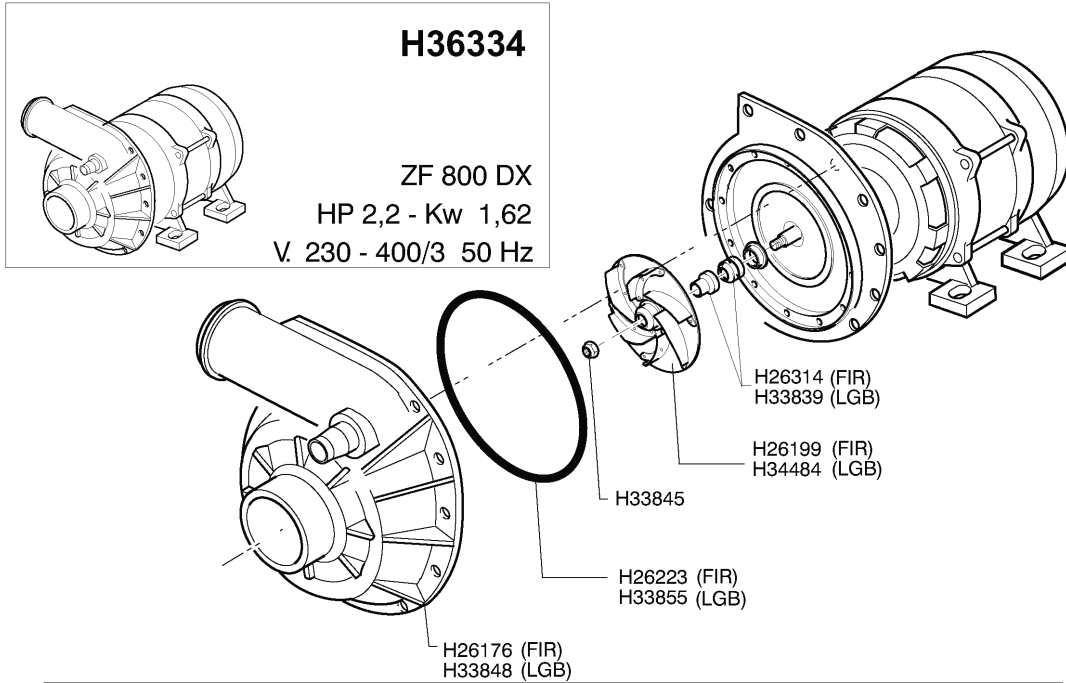

MS 06-2010

6 - Pump

CODE	DESCRIPTION
200416	GASKET D. 3/4"
201036	INLET HOSE 2 MT
260404	STAINLESS STEEL NUTS D6 UNI 55
260504	ST/ST FLAT WASHER D6
260512	ST/ST GROWER WASHER D6
300508	LOCK NUT 3/4"
301001	NIPPLE FE-ZN 3/4"
631206	CONDENSER 10MF. 450V 85C
H25342	RINSE PUMP GF90
H26176	PUMP VOLUTE GF/GFS90 (FIR)
H26199	PUMP IMPELLER GF/GFS90 (FIR)
H26223	PUMP GASKET (FIR)
H26314	MECHANICAL SEAL GF/GFS90 (FIR)
H28218	PUMP FEET
H31661	CONNECT.1" - 3/4" MM
H33839	SEAL FOR PUMP GF90
H33845	SCREW FOR PUMP IMPELLER GF90
H33848	PUMP VOLUTE GF90
H33855	JOINT FOR GF90 PUMP
H34484	PUMP IMPELLER GF90
H35371	SEAL FOR PUMP
H36334	WASH PUMP 2,2HP 230/400-3 50HZ

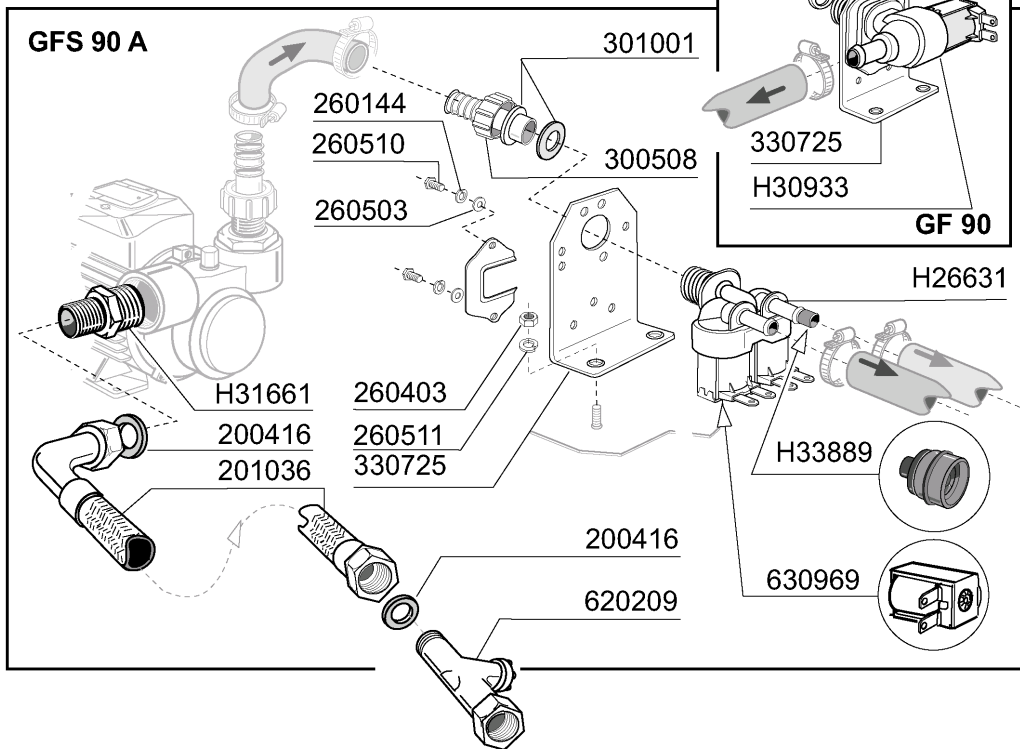
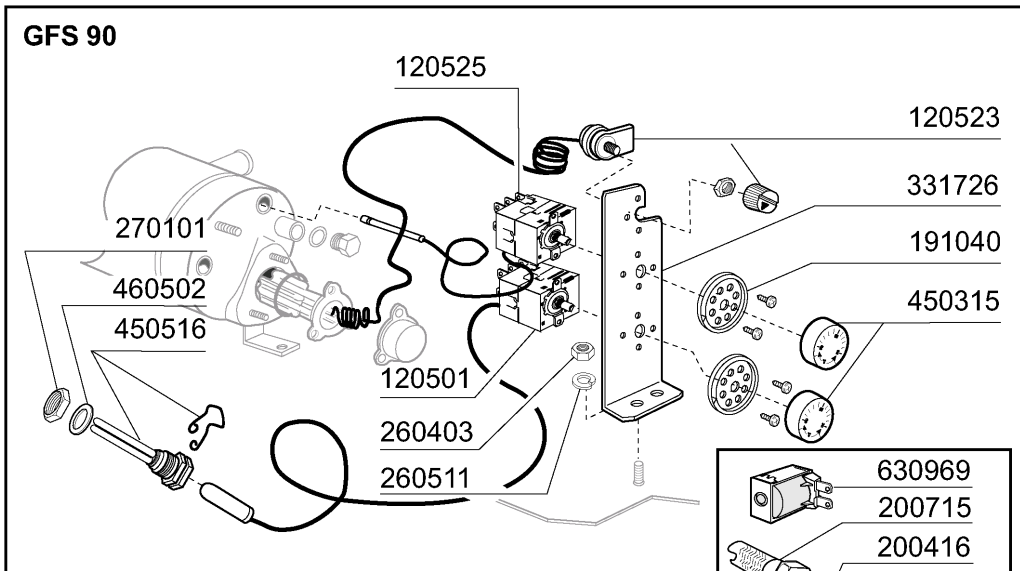

MS 06-2010

7 - Thermostat/Solenoid Valve Group

CODE	DESCRIPTION
120501	THERMOSTAT 30/90°C
120523	SAFETY THERMOSTAT 110°C
120525	BOOSTER THERMOSTAT 2 TEMPERAT.
191040	FRAME F.THERMOSTAT KNOB
200416	GASKET D. 3/4"
200715	HOSE WATER INLET 2M STAINL.ST
201036	INLET HOSE 2 MT
260144	SCREW TE 4X6
260403	NUTS D.5
260503	STAINL.STEEL FLAT WASHER D5 UN
260510	GROWER WASHER D.4
260511	GROWER WASHER D.5
270101	HEXAGON LOCK NUT 1/2"
300508	LOCK NUT 3/4"
301001	NIPPLE FE-ZN 3/4"
330725	STANDARD BRACKET F.SOLEN.VALV
331726	BRACKET FOR 3 THERMOSTATS
450315	KNOB F. THERMOSTAT 90°C
450516	THERMOSTAT SHIELD FOR 2 TERMOS
460502	GASKET 30X21X2
620209	INLET WATER FILTER
630969	COIL S4216 220/50HZ
H26631	2-WAY SOLENOID VALVE GF90
H30933	SOLENOID VALVE AQUA+
H31661	CONNECT.1" - 3/4" MM
H33889	RIDUTT.ELETTROV.RIGENER.GF90A

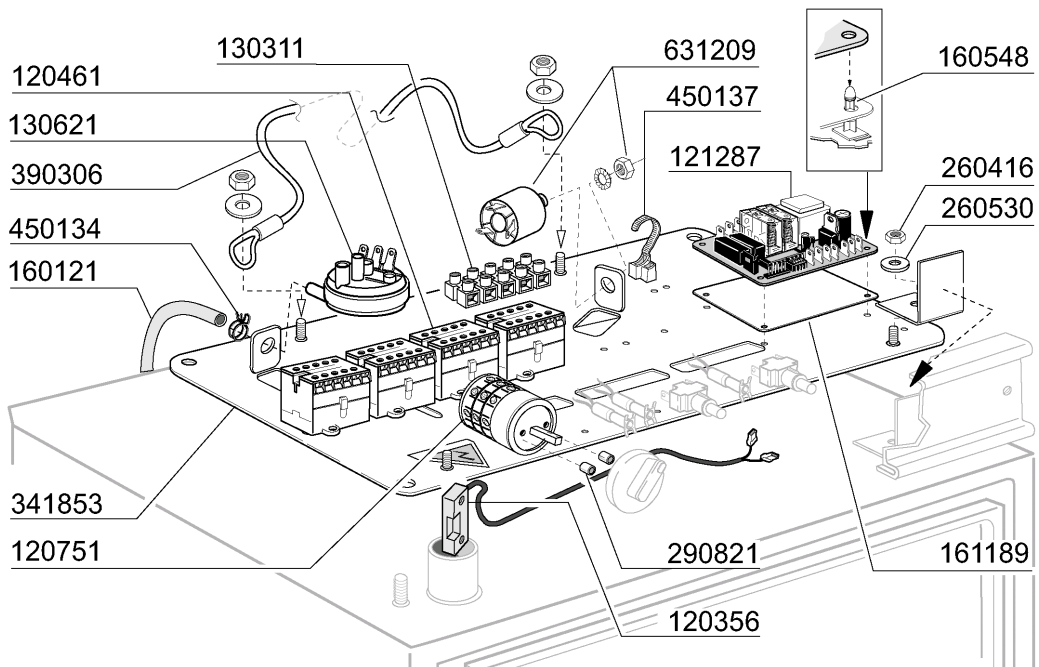
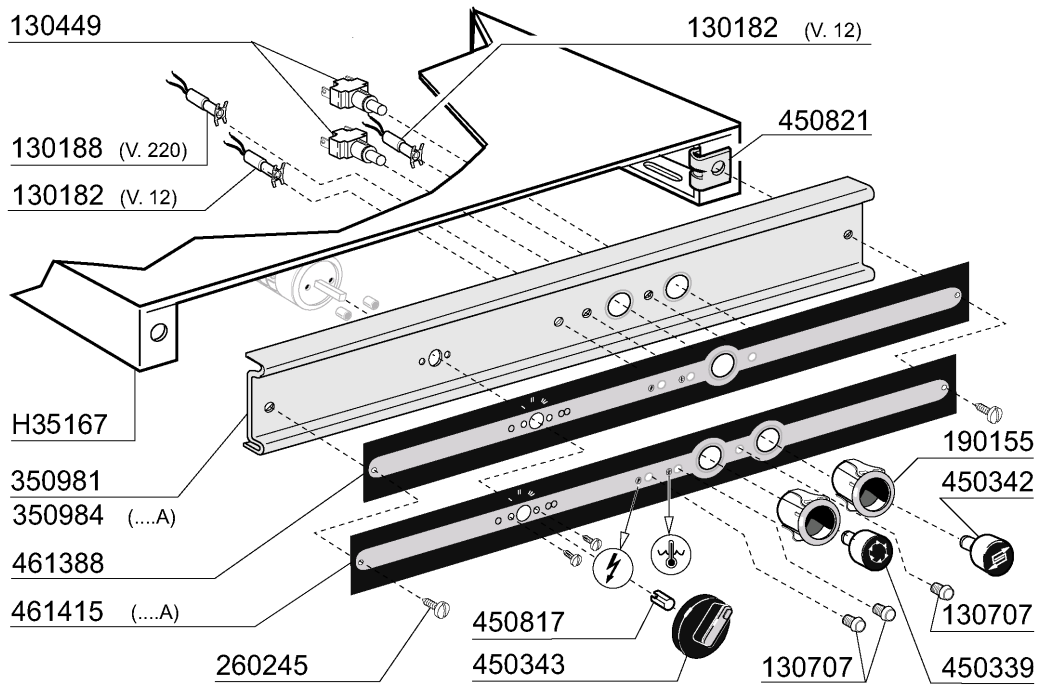

MS 06-2010

8 - Control Box

CODE	DESCRIPTION
120356	DOOR MAGN.SWITCH
120461	CONTACTOR ABB B6-30-01 220V
120751	4 POLE SWITCH 16A
121287	ELECTRONIC TIMER
130182	GREEN LAMP 12V
130188	GREEN LED 220V
130311	TERMINAL BLOCK
130449	PUSH BUTTON BR-BC-FC
130621	PRESSURE SWITCH FOR BC HR 45/2
130707	TRANSPARENT LENS COVERS (C-SER
160121	HOSE EPDM D. 5 X 9
160548	DISTANZ.TASTIERINI ELETTRONICI
161189	COVER
190155	BUTTON HOLDER
260245	SPECIAL SCREW TC 3,5X16
260416	STAINLESS STEEL NUTS M6
260530	STAINL.ST WASHER 7X22X2
290821	DISTANCE PIECE FOR SWITCH
341853	SUPPORT
350981	SUPPORT
350984	SUPPORT
390306	CABLE
450134	ELASTIC HOSE CLIP D.9,3/8,8
450137	COLLAR CONNECTION WITH BASE 31
450339	PUSH BUTTON "CYCLE"
450342	REGENERATION SWITCH
450343	BLUE SWITCH
450817	RIVETTO ALLUM.ADV.18010406
450821	SPRING CLIP FASTENER SNU 3634
461388	CONTROL PANEL GF90
461415	CONTROL PANEL GF90A
631209	ANTI-NOISE FILTER
H35167	UPPER COVER GF90

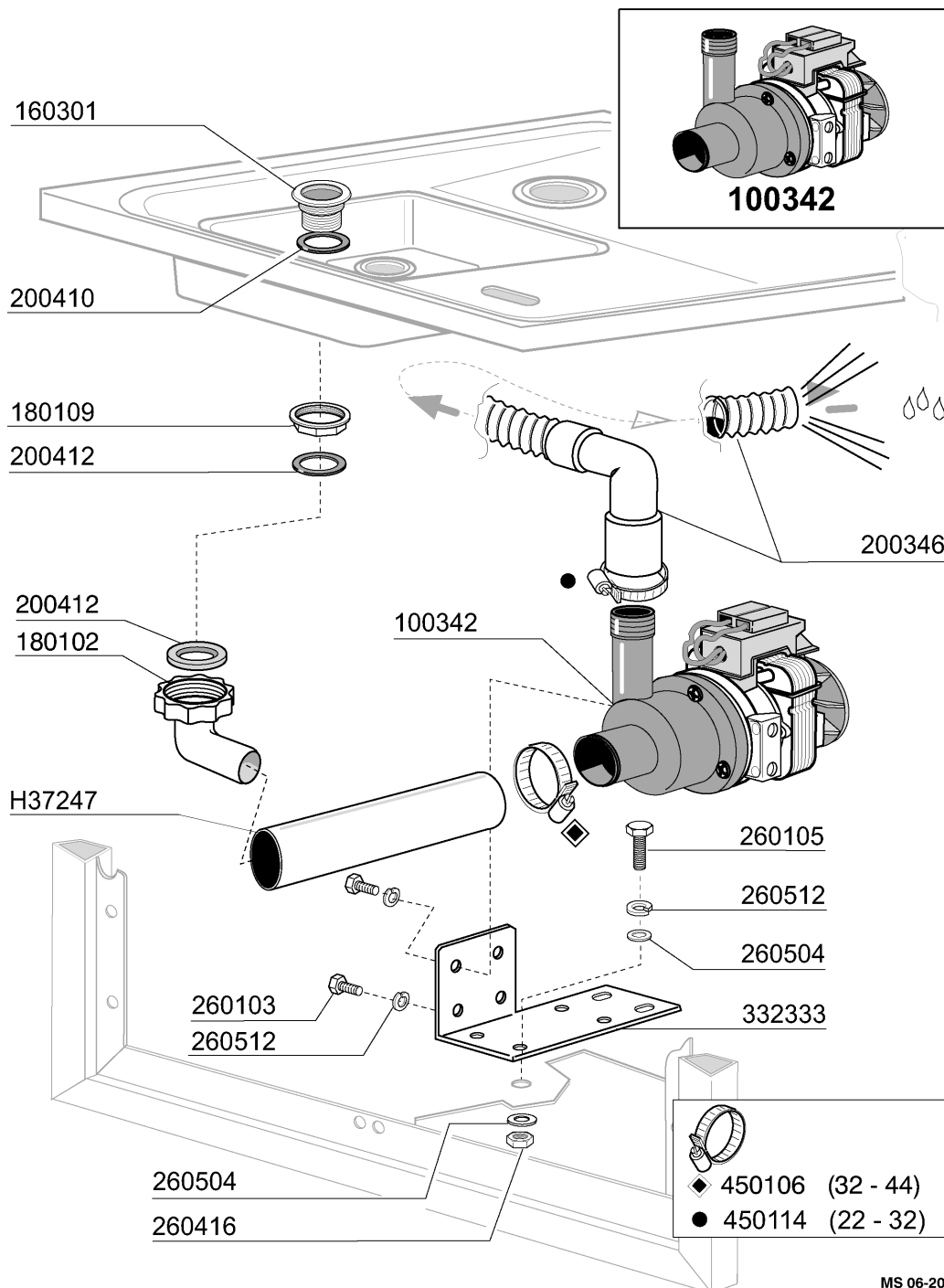

MS 06-2010

9 - Drain pump

CODE	DESCRIPTION
100342	DRAIN PUMP 100 W 220V
160301	DRAIN OUTLET 1"1/2 C-S-N
180102	DRAIN PIPE NUT 1"1/2 F45-55
180109	LOCK NUT 1 1/2"
200346	DRAIN HOSE GLASSWASHER
200410	DRAIN OUTL.WASH.1 1/2"65X47X2
200412	GASKET DRAIN 11/2" 45X33X3
260103	SCREW TE 6X12
260105	SCREW TE 6X20
260416	STAINLESS STEEL NUTS M6
260504	ST/ST FLAT WASHER D6
260512	ST/ST GROWER WASHER D6
332333	BRACKET FOR DRAIN PUMP
450106	CLAMP FE ZN 32-44 H=12,2
450114	CLAMP FE ZN.22-32 H=12,2
H37247	DRAIN PUMP INLET HOSE

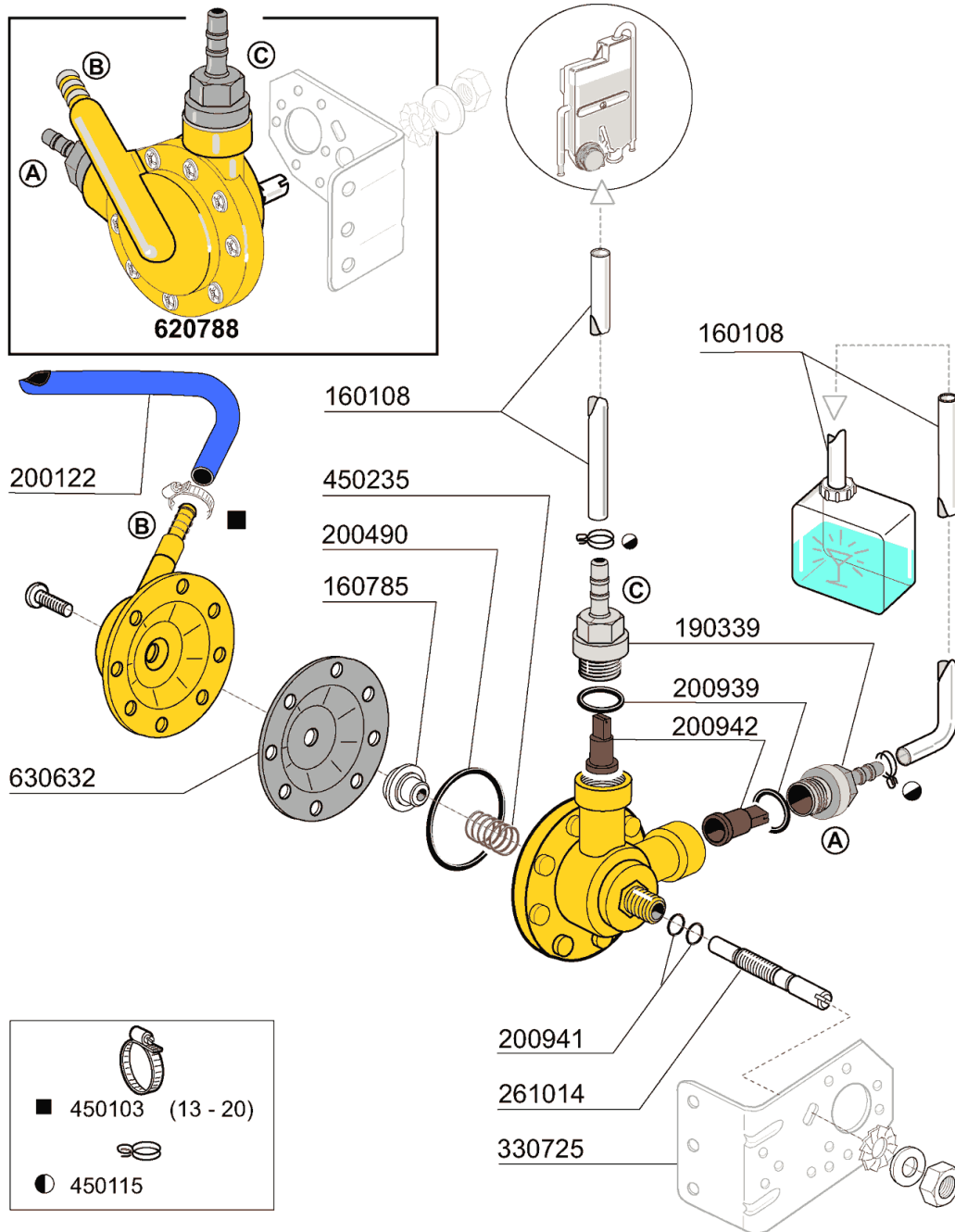

04 - 2007 | S. AG.

10 - Rinse aid injector

CODE	DESCRIPTION
160108	INJECT.INLET HOSE D.8X5
160785	GUIDE FOR SPRING RINSE AID INJ
190339	RINSE AID INJECTOR CONNECTION
200122	HOSE 11X19
200490	PROTECTION GASKET MOD.ADV.
200939	OR GASKET
200941	OR GASKET
200942	VALVE RINSE INJECTOR HVD
261014	SCREW
330725	STANDARD BRACKET F.SOLEN.VALV
450103	CLAMP FE ZN. 13-20 H=9
450115	ELASTIC CLAMP D.8,3/7,8
450235	SPRING RINSE AID INJECTOR
620788	RINSE AID INJECTOR H21428
630632	DIAPHRAGM RINSE INJECTOR HVD

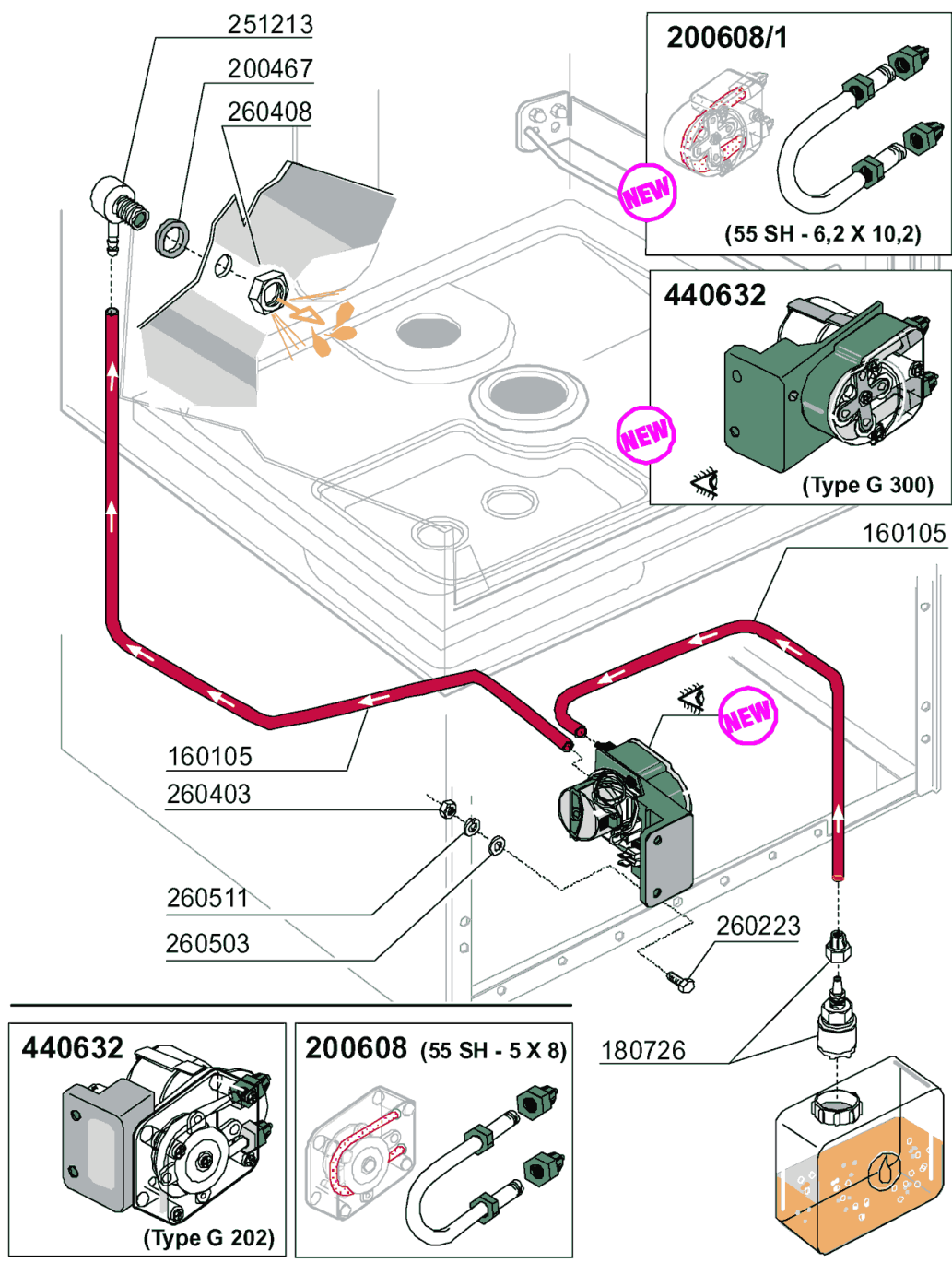

09 - 2007 | S. AG.

11 - Detergent dispenser

CODE	DESCRIPTION
160105	INJECT.INLET HOSE D.6X4
180726	STREINER FOR RINSE AID INJECTO
200467	DUTRAL GASKET F. AIR TRAP
200608	DETERGENT DISPENSER HOSE
200608/1	HOSE FOR DISPENSER GERMAC G300
251213	INJECTIOR S/S FOR DETERGENT IN
260223	M5X12 MSH/HD SCREW SPECIAL S/S
260403	NUTS D.5
260408	S/S NUTS D.12
260503	STAINL.STEEL FLAT WASHER D5 UN
260511	GROWER WASHER D.5
440632	DETERGENT INJECTOR

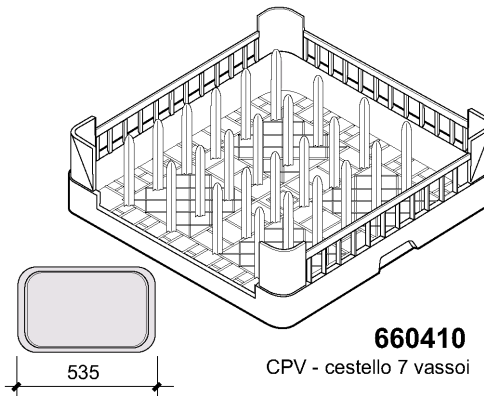
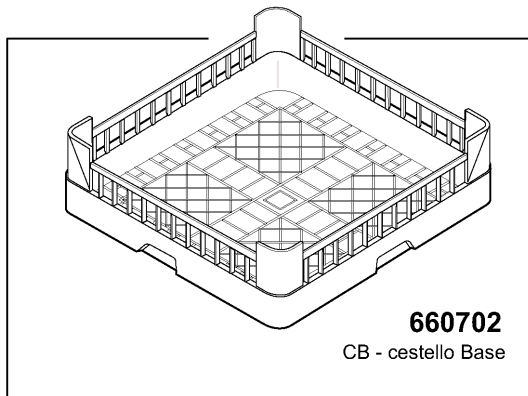
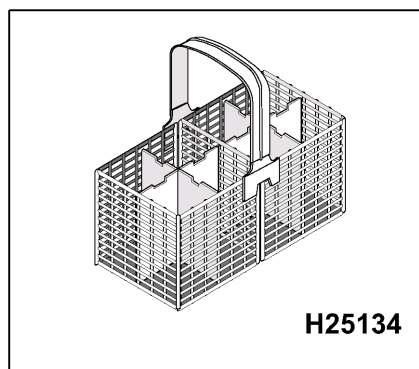
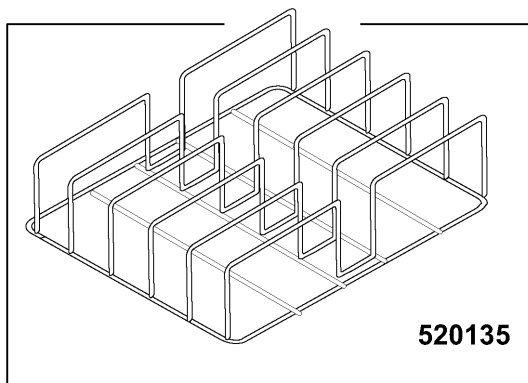
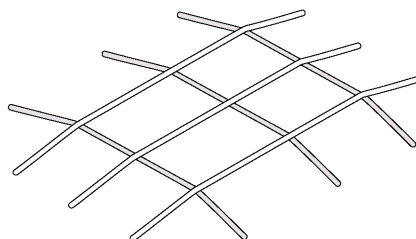
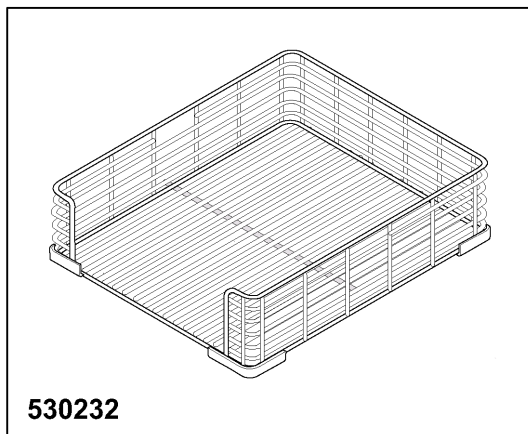

12 - Rack

CODE	DESCRIPTION
520135	INSERTO TEGLIE GF90
530232	BASE RACK 600X500MM
660410	CEST.VASSOI GRANDI CPV MONT.
660702	BASE RACK 50X50
H25134	CUTLERY RACK GF90
H35236	COMPARTMENT DIVIDERS GF90